

ChinaBalers

Y82-P & HVA PET Bottle Baler

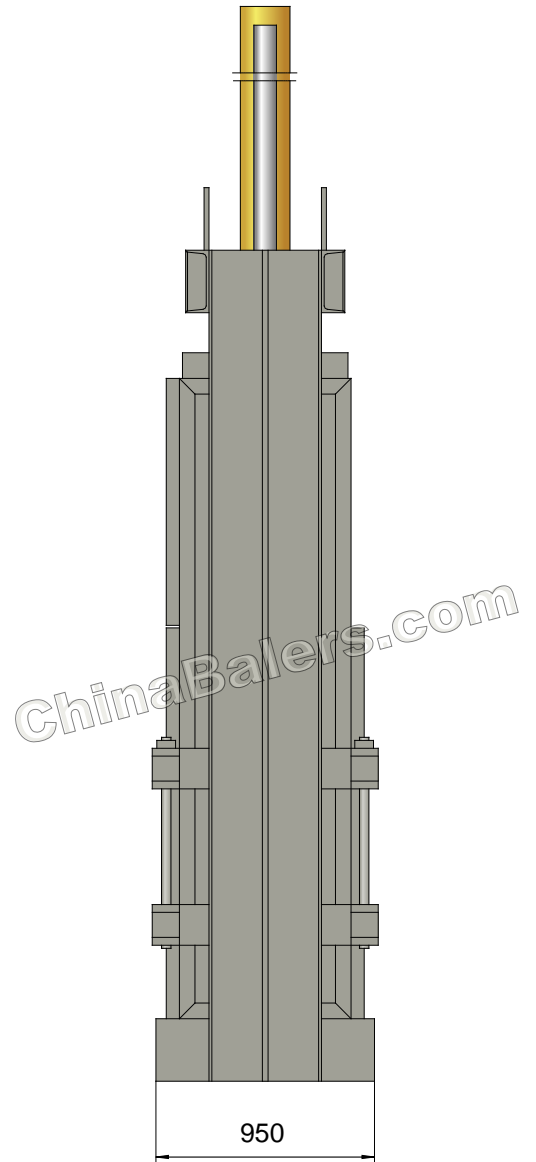

Y82-30P

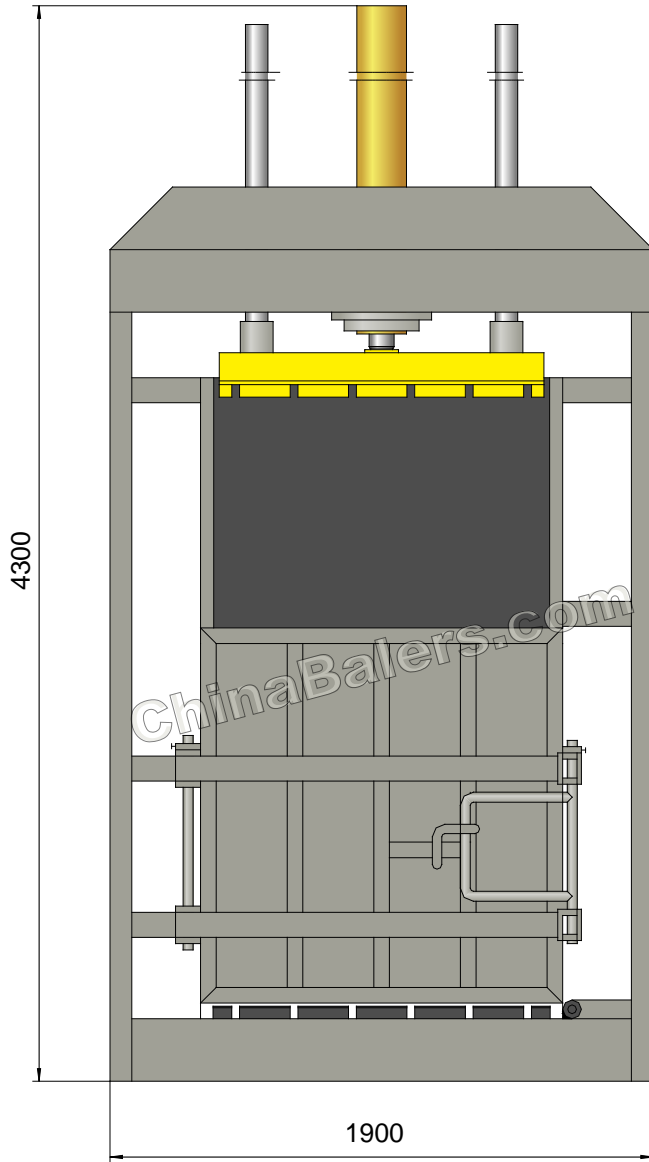
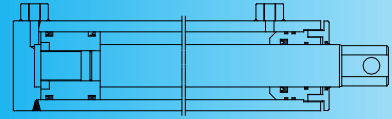

Y82-30P

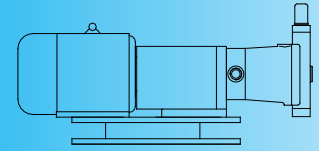

PET Bottle Baler

Model: Y82-30P

Power System (Motor)

Type:	Y160M-4
Rated Power:	11 kW
Rated Speed:	1460 rpm
Power Spec:	3PH, 50 / 60Hz

System Parameters

Main Pressure Cyl. Force:	30 Ton
Hydraulic System Pressure:	25 MPa

Hydraulic System (Pump)

Type:	40YCY14-1B
Rated Displacement:	40 ml/r
Max Operating Pressure:	31.5 MPa

Standard Configuration

NOK (JAPAN) Seal Packings for Cylinders.

Operation System

Manual Valve Operation

General Description

Main Machine Size (L×W×H):	1900×950×4300 mm
Press Box Size (L×W×H):	1100×500×2000 mm
Space Between Ram & Bottom:	Max. 1950 mm; Min. 350 mm
Bale Size (L×W):	1100×500 mm
Bale Weight (PET Bottle):	120-150 kg
Production Rate (PET Bottle):	350-450 kg/hr
Strapping:	Tempered Iron Wire, ϕ 2.8/3.2mm, 5 Lines, Manual Strapping.
Bale Discharging:	Manual Discharging
Shipping Weight:	Approx. 2.2 tons
Loading (Standard Containers):	1/2×20'GP

Hydraulic Oil Brand

Oil Tank Volume: 320 ltr

ISO VG	China	U.S.		Britain	France
	GB11118.1	CALTEX CO.	MOBIL	SHELL	ELF CO.
HM 46	46 #	Rando HD46	D.T.E46	Tellus 46	Elfolna 46
HM 68	68 #	Rando HD68	D.T.E68	Tellus 68	Elfolna 68

Above information are indicative not engaging. Rights reserved for change if necessary.

HVA40

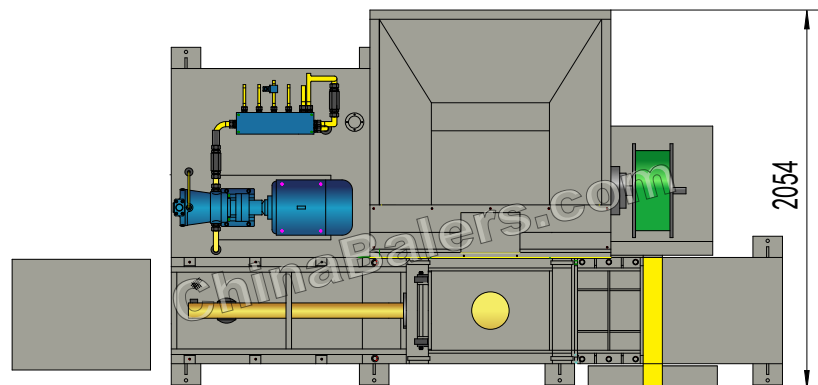
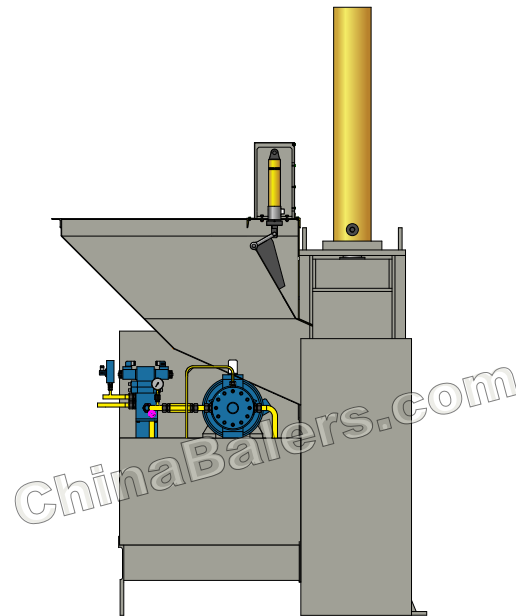
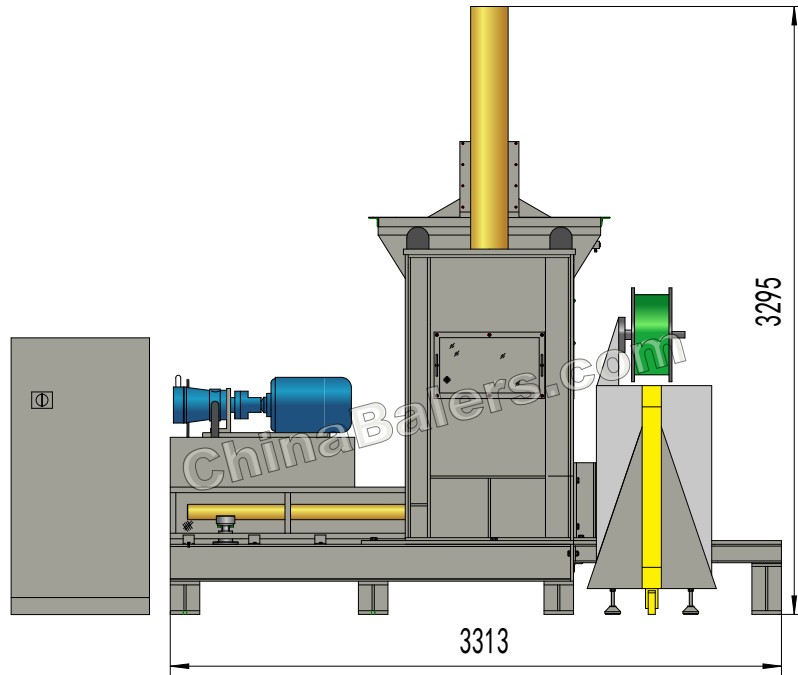
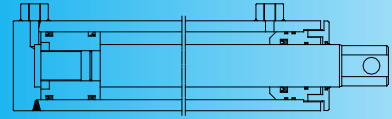

HVA40

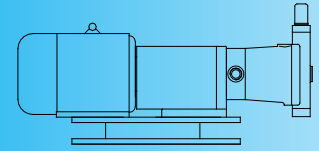

PET Bottle Baler

Model: HVA40

Power System (Motor)

Type:	Y160M-4
Rated Power:	11 kW
Rated Speed:	1445 rpm
Power Spec:	3PH, 50 / 60Hz

Hydraulic System (Pump)

Type:	40YCY14-1B
Rated Displacement:	40 ml/r
Max Operating Pressure:	31.5 MPa

Automatic Strapping MC

Strapping Strips (PP/PET):	13.5×(0.5~1.0) mm
Max. Strapping Force:	80 kgf
Frame Spec:	600×850 mm
Strapping Speed:	25~30 times/min

General Description

Main Machine Size (L×W×H):	3350×2100×3400 mm
Press Chamber Size (L×W×H):	640×430×1350 mm
Bale Size (L×W):	640×430×350 mm
Pressure on Bale Surface:	14.5 kgf/cm ²
Bale Weight (PET Bottle):	18-20 kg
Production Rate (PET Bottle):	270-300 kg/hr
Shipping Weight:	
Loading (Standard Containers):	

Hydraulic Oil Brand

Oil Tank Volume:

560 ltr

ISO VG	China	U.S.		Britain	France
	GB11118.1	CALTEX CO.	MOBIL	SHELL	ELF CO.
HM 46	46 #	Rando HD46	D.T.E46	Tellus 46	Elfolna 46
HM 68	68 #	Rando HD68	D.T.E68	Tellus 68	Elfolna 68

System Parameters

Main Pressure Cyl. Force:	40 Ton
Open Door Cyl. Force:	6.5 Ton
Bale Ejection Cyl. Force:	10 Ton
Sweeping Cyl. Force:	4 Ton
Baffle Cyl. Force:	6.5 Ton
Hydraulic System Pressure:	20 MPa
Idle Cycle Time:	230 Sec
Total Installed Power:	13.5 kW
Bale Density (PET):	≈ 200 kg/m ³

Standard Configuration

NOK (JAPAN) Seal Packings for Cylinders.

Operation System

Mitsubishi PLC Operation.

Above information are indicative not engaging. Rights reserved for change if necessary.



Soochow Baling Machinery Ltd.
Jiangsu Huahong Technology Stock Co., Ltd.

Factory: Zhouzhuang, Jiangyin, Jiangsu

Office: Rm 1202, SIPCTD Bldg, No. 381 Suzhou Avenue East,
Suzhou Industrial Park, Suzhou, Jiangsu 215028 China

Tel: +86 512 6255 1141 **Fax:** +86 512 6255 1142

Email: info@chinabalers.com; chinabalers@foxmail.com

Website: www.chinabalers.com; www.chinabalers.net